

ZHP-1550 Solenoids Pump

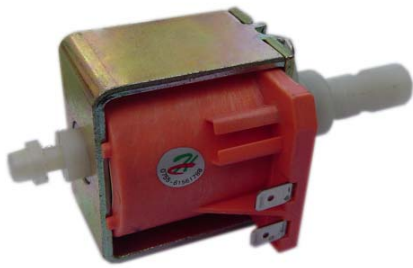

总重量 Total Weight: 450g
应用范围: 用于咖啡机、清洁机等
APPLICATION: Coffee machine And Cleaner ect

综合特性 GENERAL FEATURES

电气连接 (交流) 直接安装
ELECTRICAL CONNECTION (AC) made as shown on the diagram

(直流) 需要使用一个方波脉转换器
(DC) requires the use of a square waves impulse converter

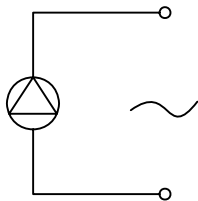

空载时间 ≤3分钟
NONLOADED TIME ≤3minute

寿命 10000循环
WORKLIFE 10000 CYCLE

工作周期 1分钟
WORKCYCLE 1Min

活塞和弹簧 高耐腐蚀性不锈钢
PISTON AND SPRING stainless steel high corrosion resistance

流体 水和无腐蚀性介质
FLUIDS water and non corrosive media

抽吸距离 泵体与液面高度差按100±10cm, 进水侧胶管长为100±10cm, 抽吸出水时间≤10Sec
SUCTION PREVALENCE Height (Pump)-Height (Liquid level) =100±10cm, the length of inlet host is 100±10cm, the time of pump water≤10Sec

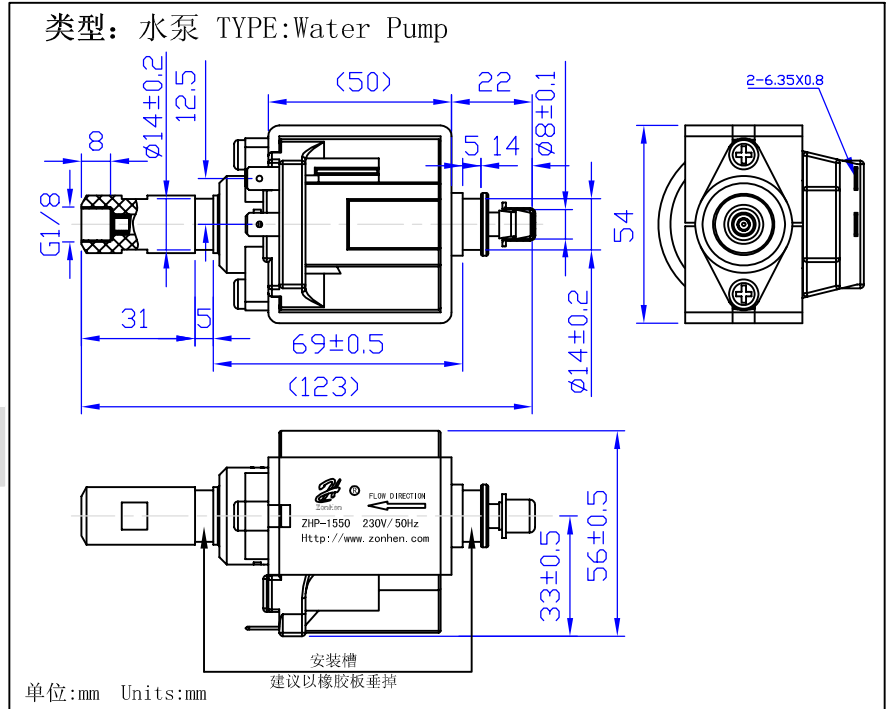

COIL SPECIFICATION (at 20° C)

Coil Sensitivity	Duty Cycle (%)	Nominal voltage (VAC)	Nominal current (A)	Coil Resistance (Ω) ±10(%)	Power Consumption (W)	Max "ON" time (Sec)	Max Pressure (Bar)	Max Flow Rate (cc/min)
ZHP-1550AF	50	230	1.39	165	65	60	15	750
ZHP-1550BF	50	120	2.22	54	54	60	2.5	700
ZHP-1550CF	50	230	1.39	165	65	60	20	600
ZHP-1550DF	50	230	1.39	165	65	60	20	600

CHARACTERISTICS (Typical data at 20° C)

